

Linear Slide

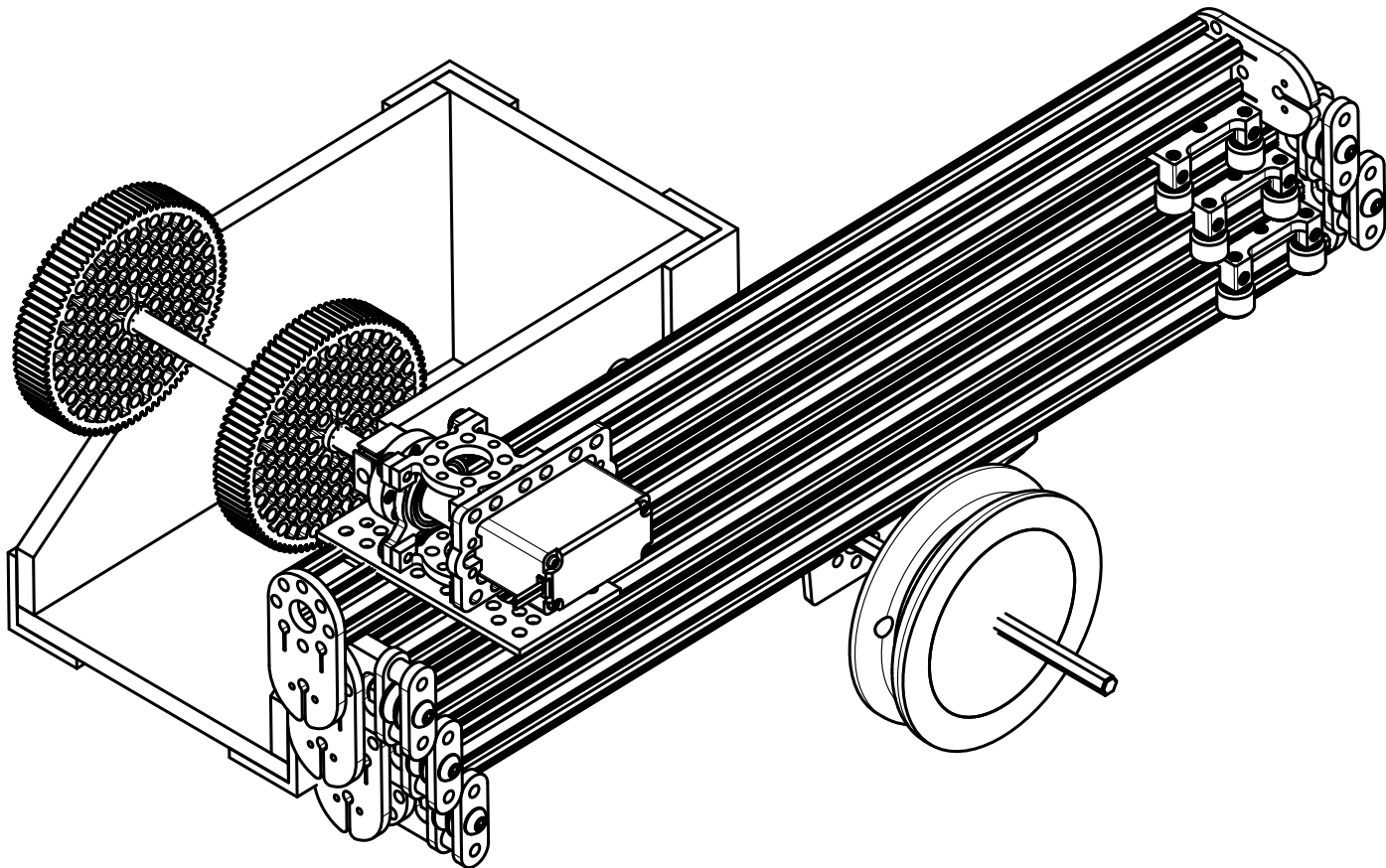

2

1

Top

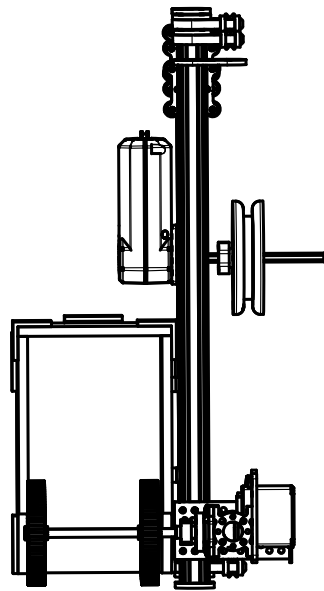

Isometric

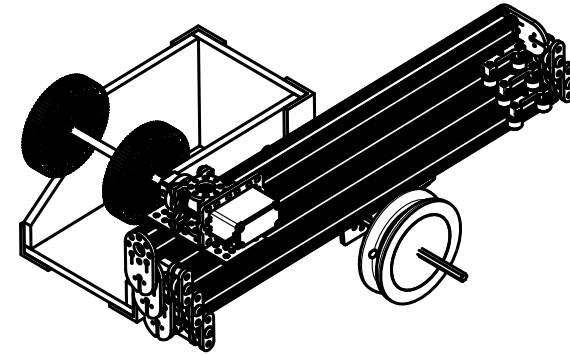

Right

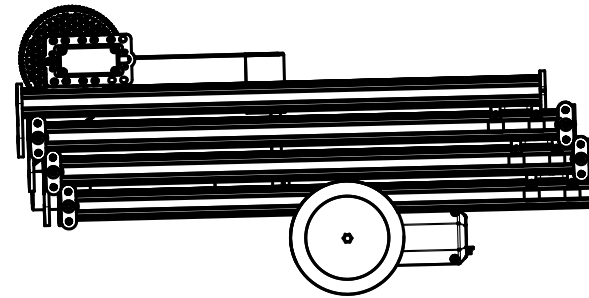

Front

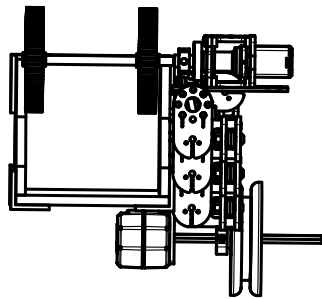

UNLESS OTHERWISE SPECIFIED,
DIMENSIONS ARE IN INCHES

.XX = ±.0-
.XXX = ±.00-
.XXXX = ±.000-
ANGULAR = ± °
FRACTIONAL = ±

SURFACE FINISH

DO NOT SCALE DRAWING

BREAK ALL SHARP EDGES AND
REMOVE BURRS

THIRD ANGLE PROJECTION

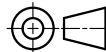

NAME DATE

DRAWN DREW BUSCH 02/04/2019

CHECKED Mark Hazen 9/19/19

APPROVED Kristi Hazen 2/19/19

TITLE Linear Slide

SIZE DWG NO. 3 REV.

SCALE 1:5 WEIGHT SHEET 2 of 5

2

1

B

B

A

A

2

1

Isometric view

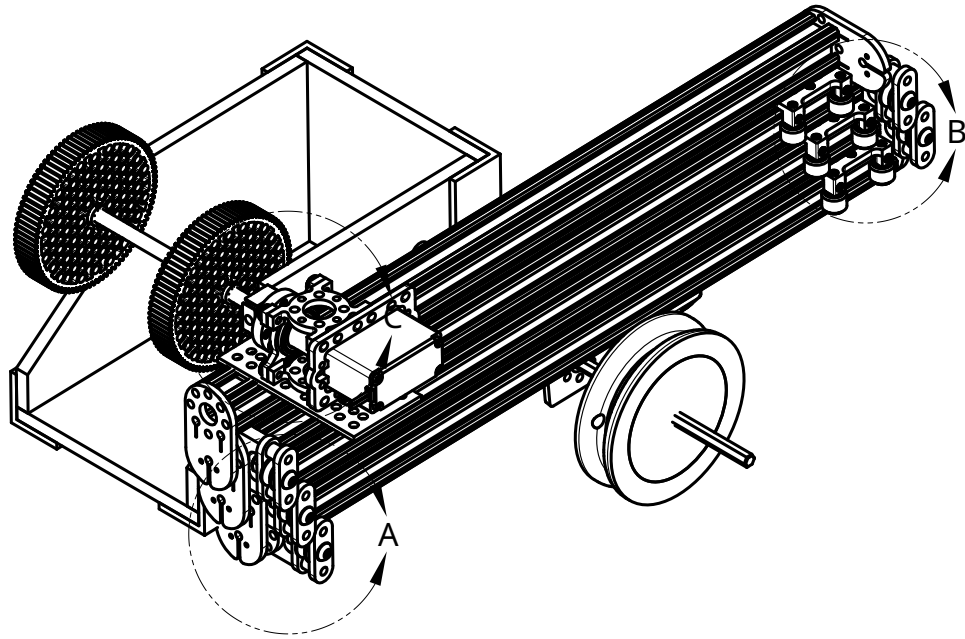

front bearing system

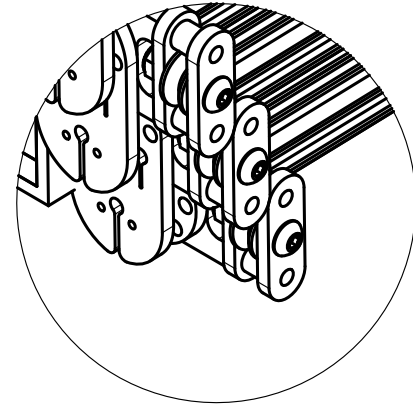

DETAIL A
SCALE 2:3

servo mount and servo block

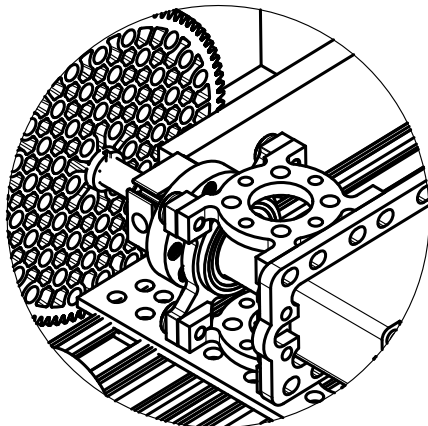

DETAIL C
SCALE 2:3

rear bearing and slide rollers system

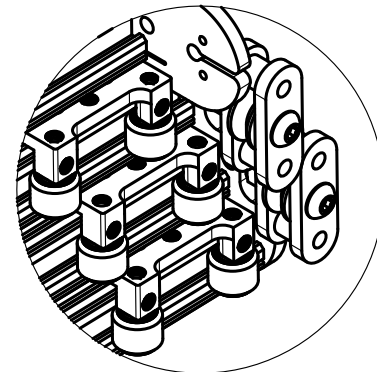

DETAIL B
SCALE 2:3

DWG NO.	3	SIZE	SCALE	1:3	SHEET	3 of 5	REV.
---------	---	------	-------	-----	-------	--------	------

2

1

B

B

A

A

2

1

Right View

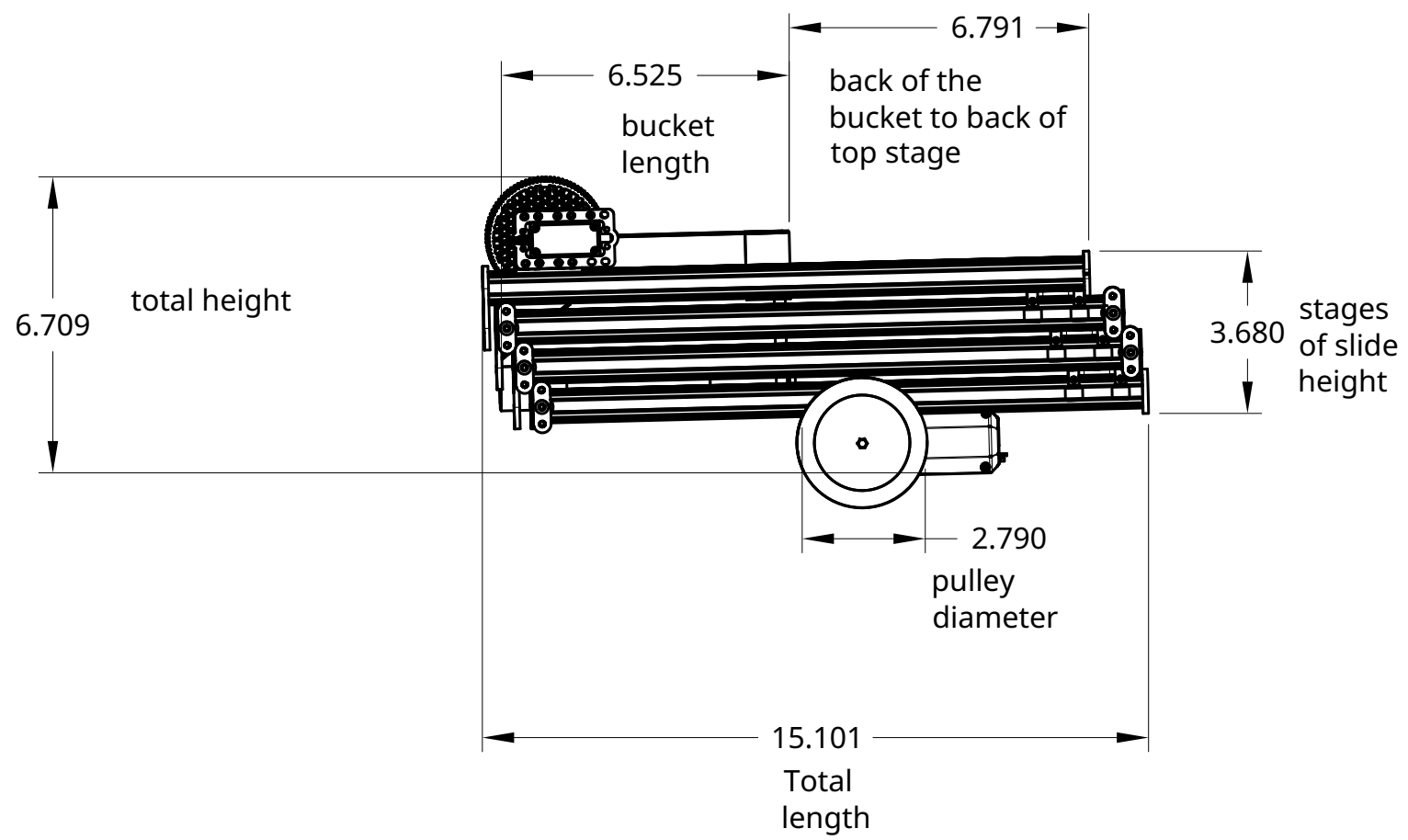

B

B

A

A

2

1

DWG NO.	3	SIZE	SCALE	1:4	SHEET	4 of 5	REV.
---------	---	------	-------	-----	-------	--------	------

2

1

Front View

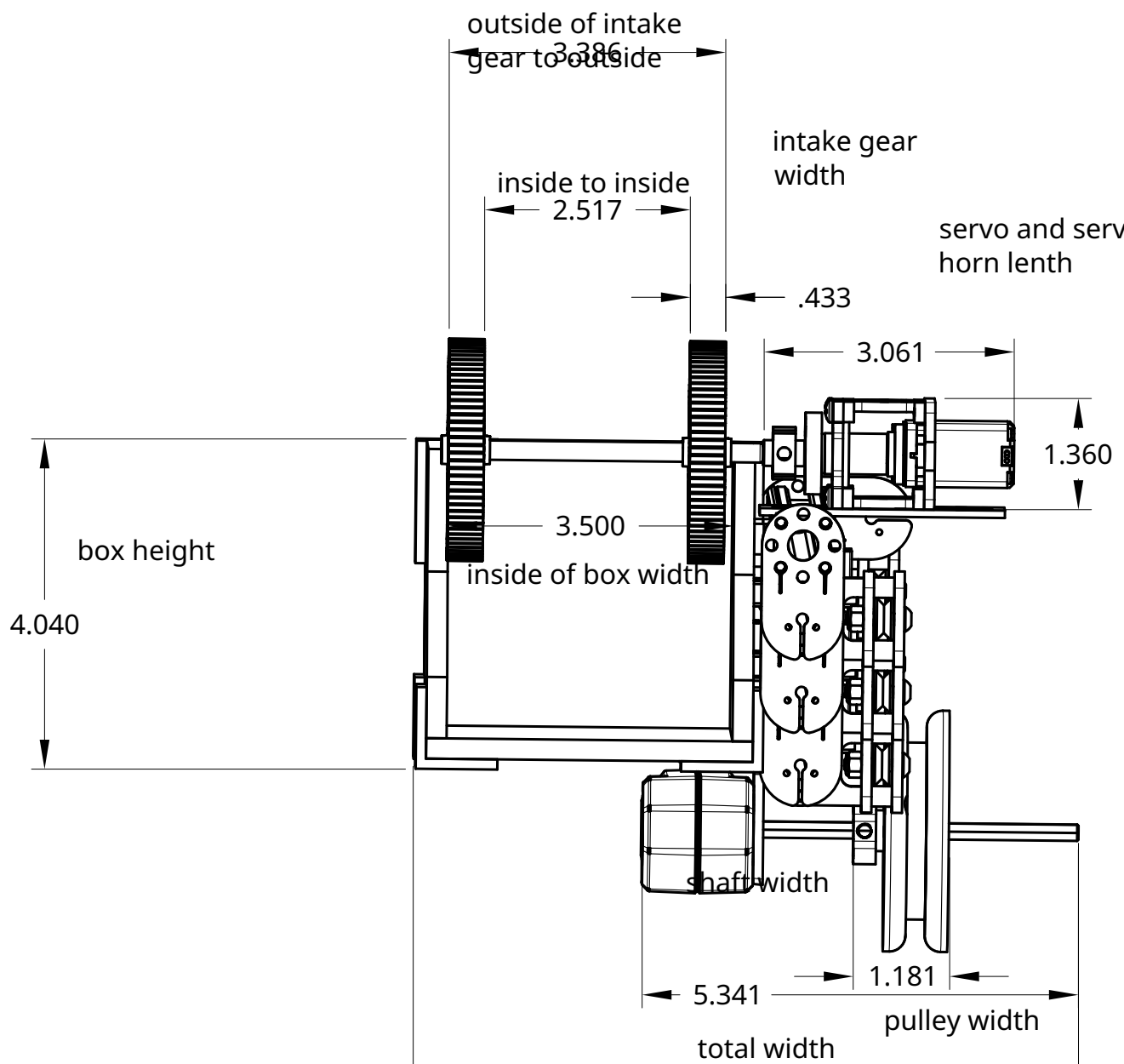

B

B

A

A

2

1

DWG NO.	3	SIZE	SCALE	1:2	SHEET	5 of 5	REV.
---------	---	------	-------	-----	-------	--------	------